

A Report

On

**“Industrial Visit – Wanakbori Thermal power station and Oreva
Hydro power station”**

For the Students of Mechanical Engineering Department. (Semester – V)

On 25th and 26th September, 2019.

- **Objective:** “Training and Exposure on the working of a thermal and hydro power plant and its technology related to the subject of Fluid Power Engineering and Heat Transfer in Sem V and Power Plant Engineering in Sem VII.”
- **Venue:** “Wanakbori Thermal Power Station and Oreva Hydro power station, Wanakbori.
- **Number of Students:** 161 (V semester, Mechanical Engineering)

Faculty Coordinator's:

GUJARAT STATE ELECTRICITY LTD.

1. Mr. Tushar M. Thakar (Asst. Prof. Mechanical Engg. Dept.)
2. Mr. Abrarkhan Pathan (Asst. Prof. Mechanical Engg. Dept.)
3. Mr. Vishal Acharya (Asst. Prof. Mechanical Engg. Dept.)
4. Mrs. Nemisha Goswami (Asst. Prof. Mechanical Engg. Dept.)
5. Mr. Pratik Moradiya (Asst. Prof. Mechanical Engg. Dept.)
6. Mr. Manish Patel (Asst. Prof. Mechanical Engg. Dept.)
7. Mr. Milan Trivedi (Asst. Prof. Mechanical Engg. Dept.)
8. Mr. Pravin Zinzala (Asst. Prof. Mechanical Engg. Dept.)

Time: 6:15 AM to 8:30 PM

Key persons of Industry:

Industrial Person to whom we are thankful to for explaining regarding plant is Mr. Gandhi sir, Mr. M.P.Singha for their exceptional work and contribution and Chief engineer Parmar sir for giving permission for visit.

OVERVIEW:-

1.1 Wanakbori Thermal Power Station

The Wanakbori Thermal Power Station is located near Wanakbori Dam on the bank of Mahi River in Kheda District. It is a Coal Based Power Station. There are seven units of 210 MW each with a total installed capacity of 1470 MW. All the above units are of BHEL make. Commissioning dates of unit no. 1 to 7 are 23.03.1982, 15.01.1983, 15.03.1984, 09.03.1986, 23.09.1986, 18.11.1987 and 31.12.1998 respectively. Following is the line diagram of the plant –

Gujarat State Electricity Corporation Limited (GSECL) was incorporated in August 1993 and is registered under the Companies Act, 1956 with the objectives to initiate a process of restructuring of Power Sector and to mobilize resources from the market for adding to the generating capacity of the State and improving the quality and cost of existing generation. The Company was promoted by erstwhile Gujarat Electricity Board (GEB) as it's wholly owned subsidiary in the context of liberalization and as a part of efforts towards restructuring of the Power Sector. The Memorandum and Articles of Association of GSECL envisage a wide spectrum of activities to improve the electricity infrastructure of Gujarat. GSECL has initiated its activities in the field of Generation of Power.

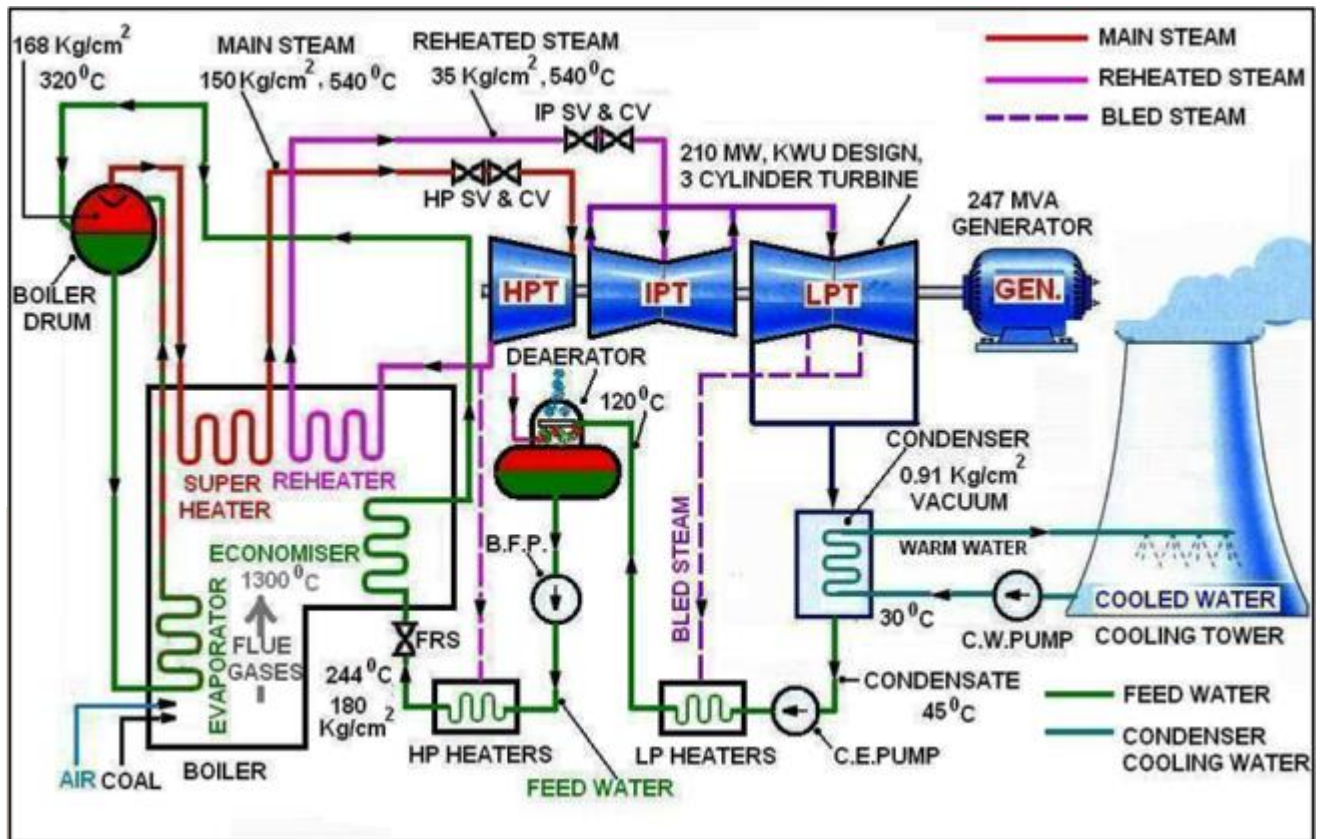

The Government of Gujarat (GoG) has also given to the GSECL the status of Independent Power Producer (IPP) with approval to undertake new power projects. The Company commenced its commercial operation in the year 1998. However, the operations of GSECL were limited to Power Stations units Gandhinagar #5, Wanakbori #7, Utran GBPS & Dhuvaran CCPP till the complete unbundling of erstwhile GEB was undertaken, i.e. up to 31st March 2005.

GUJARAT STATE ELECTRICITY LTD.

As a part of the reform process, the Government of Gujarat has unbundled the various functions of GEB. As a result of this unbundling, Gujarat State Electricity Corporation Limited (GSECL) has taken up the responsibility of electricity generation. Electricity Transmission has been entrusted to the already existing company - GETCO. Distribution network in the state has been split up among four distribution companies, which cater to the northern, central, southern, and western parts of the state respectively. All these companies have been structured as subsidiaries of a holding company, Gujarat Urja Vikas Nigam Limited (GUVNL). GUVNL is also the single

bulk buyer in the state as well as the bulk supplier to distribution companies. It will also carry out the trading function in the state.

The main objective of the industrial visit was to get all the students acquainted with actual industrial environment and to observe that how power is generated, different controls required and to understand function of numbers of electrical & mechanical machines and an interdisciplinary approach.

VISIT 1. WANAKBORI THERMAL POWER STATION **(WTPS)**

The number of students who attended the visit was 161 accompanied by 8 faculty members. On the day of visit, the students and the faculty left the college campus at 6:10 am and reached the venue at 8:10 am. The students as well as faculty travelled on four buses hired by LJET accordingly.

First batch were sent to visit Wanakbori thermal Power station; meanwhile second batch was sent to visit Oreva Hydro power station located in Balasinor which is around 18 km far from Wanakbori.

Initial seminar on the working of WTPS was given by Mr. Gandhi (Training Officers) to the students. They explained the working cycle of thermal power station with power point presentation and videos. Students observed various small scale models of equipments used in the power plant.

Under their guidance and along with 8 faculties, students were then led to visit various plant departments such as boiler room, feed pump department coal and ash handling area, cooling towers.

To put it briefly, following sections of the WTPS were visited.

- Training center

- Coal and ash handling plant
- Boiler section
- Turbine/Generator floor
- Electrical control room
- Cooling tower
- Switch yard (220kV & 400 kV)

On return from the WTPS plant visit, the students were provided lunch by LJJET. After an hour lunch break they headed to the Oreva Hydropower Station.

The visit was very fruitful as students were able to observe each of energy conversion stages used in power plant starting from fuel section to switch yard. We collected very important information like practical data which are not available in books and other literature. Many of the students' doubts were cleared by the discussion with experts of the plant.

Some images taken during the visit are shown below –





GUJARAT STATE ELECTRICITY LTD.



GUJARAT STATE ELECTRICITY LTD.

L. J. INSTITUTE OF ENGINEERING AND TECHNOLOGY – AHMEDABAD.
MECHANICAL ENGINEERING DEPARTMENT





VISIT 2. OREVA HYDRO POWER STATION

OVERVIEW

The power station is an installation of 1 MW hydro-based power project, which involves a vertical full Kaplan turbine having rated capacity of 1000 kW. The power is generated at voltage of 3.3 kV, which will be stepped up to 11kV at the switchyard located in the power plant, before being fed into 66 kV Balasinor substation. "Oreva Energy Pvt. Ltd", formerly known as "Kishan Kanaiya Hydro Power Pvt. Ltd." It is an electricity generation project utilizing the hydro resources of Wanakbori Weir constructed across river Mahi in Gujarat State. The Wanakbori Weir, which was built in 1958 and is maintained by Irrigation department, provides water for crop irrigation as well. The gross annual electricity generation from the project activity is approximately 5700 MWh of Electricity with installed capacity of 1MW.

THE VISIT

The visit was completed at WTPS and after a brief lunch break, we went to visit Oreva hydro power station which is located in Balasinor (around 18km far from WTPS). The number of students was 161 in total of Mechanical branch.

The students were shown the working of the hydro power station which is connected to Mahi Dam with the help of Weir. The students were keen to gain the knowledge since this was a new and fresh topic for them and it related to their subject as well.

Some images taken at the Oreva Hydro power station are as under –



GUJARAT STATE ELECTRICITY LTD.



SUMMARY AND OUTCOME OF THE VISIT

The visit enabled the students to

- Recognize the process units – Boiler, Pumps, Condenser, Steam turbine, Generator, Electrostatic precipitator, Pulveriser, Reclaimer etc. and generate the process flow diagram.
- Identify input and output for the process.
- Experience the importance of working safety.
- Understand the concept of thermal energy conversion and estimate overall thermal efficiency of power plant.
- Understand how the product of the power plant interfaces to the world.

The visit ended at 5:00 pm, the faculties and students reached the college at around 8:30 pm. The overall response of the students was positive.

Below are listed feedbacks of few of the students

1. Learning and fruitful Experience
2. They requested to arrange similar visit in the next semester.
3. The visit has helped them to understand their subject matter easily.

Felicitation of Chief Engineer



ACKNOWLEDGEMENT

The coordinators are grateful to the College authorities, Management and the Vice President – Dr. Manish Shah (LJK Trust) for supporting them to carry out such a program and for providing the support. Secondly, the coordinators would like to thank Director (L.J.I.E.T.), who encouraged the coordinators for this program. Also, the coordinators extend their gratitude to the Head of the Department (Mechanical Engineering), who has played a major role by being there at the time of need. Last but not the least; the students did a wonderful job and the coordinators are proud of each of their students.

